

# F KE K



## LM K

- Magnetic resin for higher current and semi-magnetically shielded
- Operating temperature: -40 to +125 °C (including self-temperature rise)
- Quantity: 2000pcs

## HHDA LA F

- DC/DC converter
- LC filter

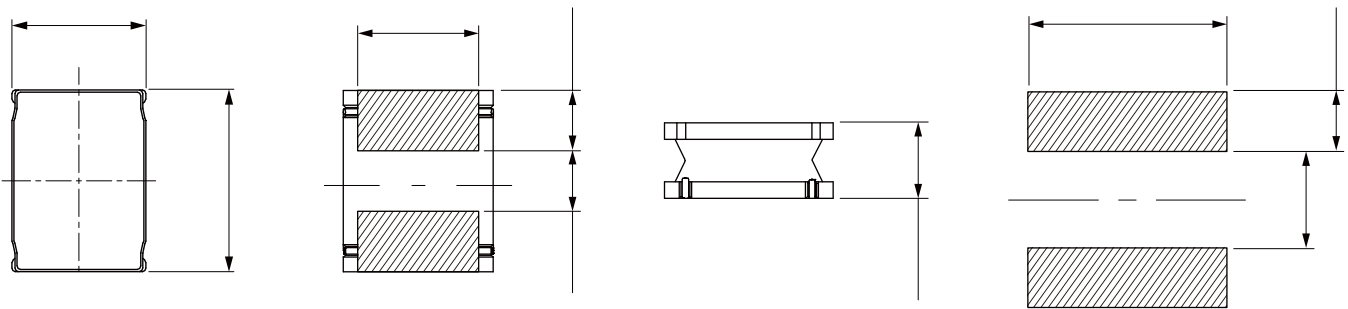

Part No	Inductance @ 1MHz/1V	Tolerance	Temperature Rise Current Typ. (A)	Temperature Rise Current Max. (A)	Current Typ. (A)	Current Max. (A)	DC Resistance Typ.	DC Resistance Max.
NRSM252012S-R24M	0.24	±20%	4.70	4.05	7.80	6.50	0.019	0.023
NRSM252012S-R33M	0.33	±20%	4.30	3.70	6.30	5.35	0.023	0.028
NRSM252012S-R47M	0.47	±20%	4.00	3.45	5.60	4.90	0.029	0.035
NRSM252012S-R68M	0.68	±20%	3.60	3.15	4.50	3.80	0.039	0.045
NRSM252012S-1R0M	1.00	±20%	3.40	3.00	4.20	3.60	0.048	0.054
NRSM252012S-1R5M	1.50	±20%	2.80	2.40	3.50	2.90	0.060	0.078
NRSM252012S-2R2M	2.20	±20%	2.15	1.90	3.00	2.60	0.100	0.120
NRSM252012S-3R3M	3.30	±20%	1.80	1.50	2.10	1.70	0.175	0.215
NRSM252012S-4R7M	4.70	±20%	1.45	1.25	1.90	1.60	0.225	0.260
NRSM252012S-6R8M	6.80	±20%	1.10	0.95	1.40	1.20	0.305	0.366
NRSM252012S-100M	10.0	±20%	1.00	0.85	1.35	1.10	0.435	0.480

Temperature rise current: the actual value of DC current when the temperature rise is T40 °C

