

| | (μH) | | Saturation | ($\text{m}\Omega$) | ($\text{m}\Omega$) |
|---------------|-------------------|------------|------------|----------------------|----------------------|
| MDCA6020-100M | | $\pm 20\%$ | | 134 | |
| | | $\pm 20\%$ | | 190 | 210 |
| MDCA6020-220M | | $\pm 20\%$ | | 236 | 280 |

△

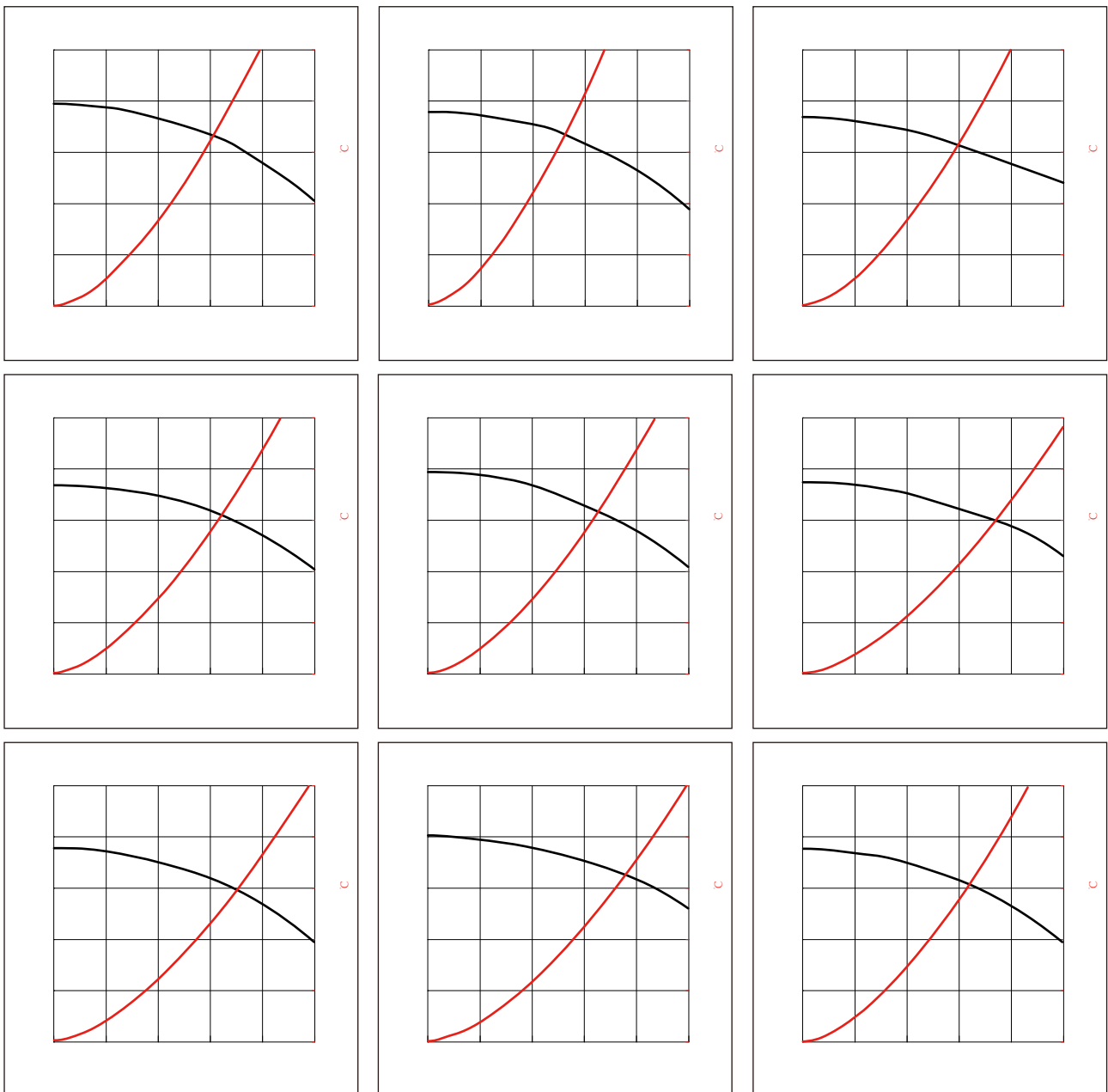

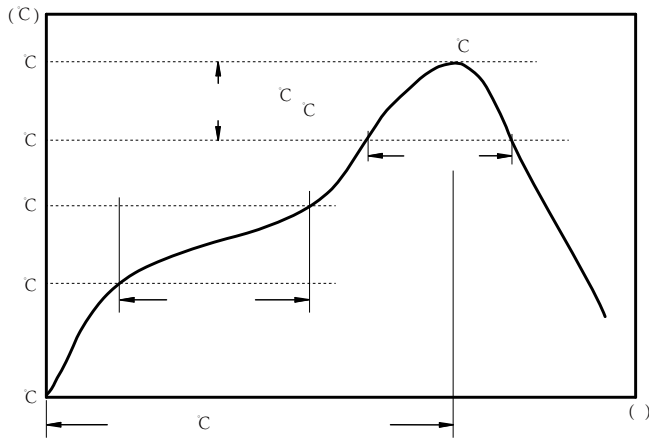

c
c
c

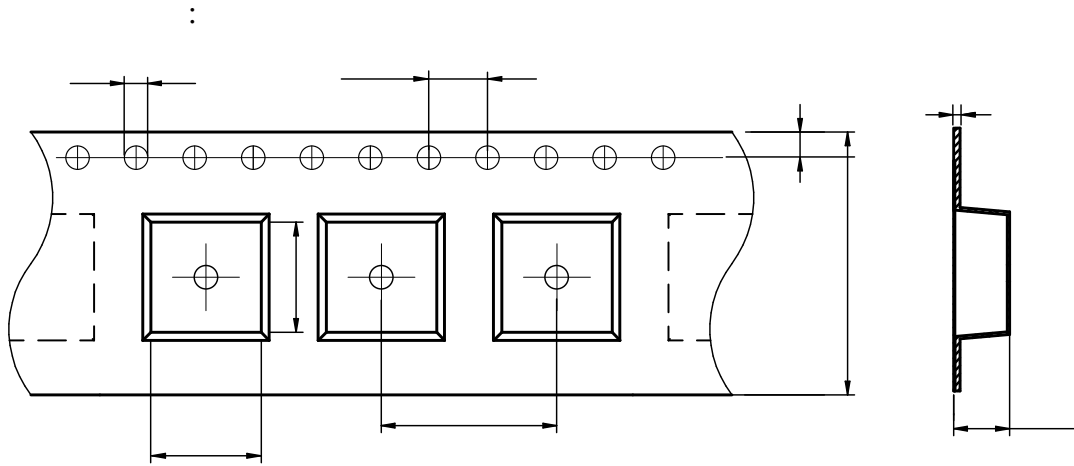

| | | | | | | | | | |
|----------|----------|----------|----------|----------|-----------|-----------|----------|-----------|------------|
| | | | | | | | | | |
| MDCA6020 | 7.0± 0.1 | 7.7± 0.1 | 1.5± 0.1 | 4.0± 0.1 | 12.0± 0.1 | 16.0± 0.3 | 2.3± 0.1 | 1.75± 0.1 | 0.35± 0.05 |

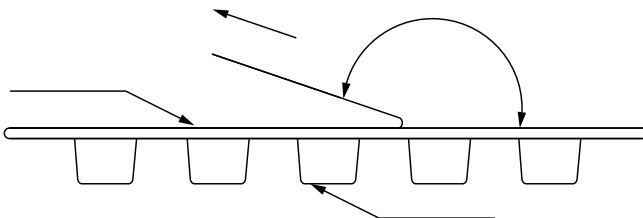

The peel force of top cover tape shall be between 0.1 to 1.3 N

| | |
|---------|-----------------------------|
| Marking | Printing Inductance+period) |
|---------|-----------------------------|

:

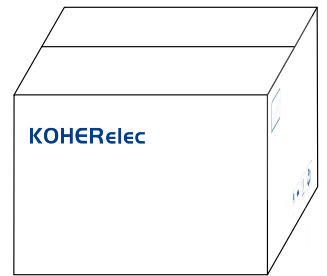
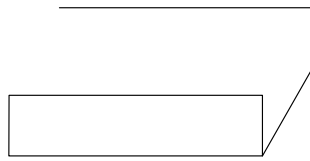
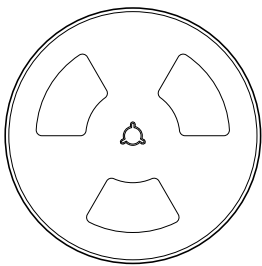
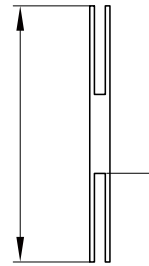
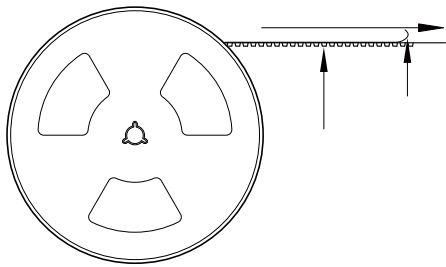

1500 Pcs/Reel

2 Reel /Inner box(3000 Pcs)

3 Inner box/Carton box(9K Pcs)

:

-
-
-
-
-
-
-
-
-