

:

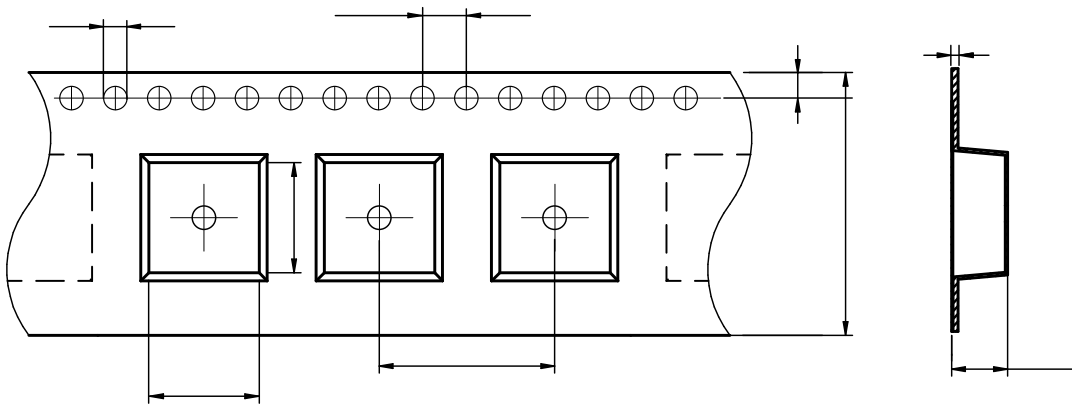

11.3± 0.1	13.0± 0.1	1.5± 0.1	4.0± 0.1	16.0± 0.1	24.0± 0.3	6.6± 0.1	1.75± 0.1	0.40± 0.05

Marking	Printing Impedance)
---------	---------------------

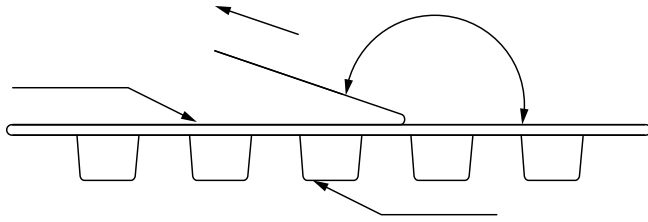

The peel force of top cover tape shall be between 0.10 to 1.17 N

:

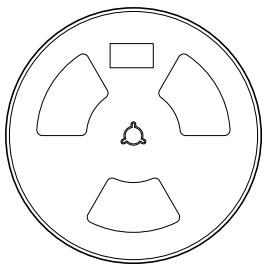
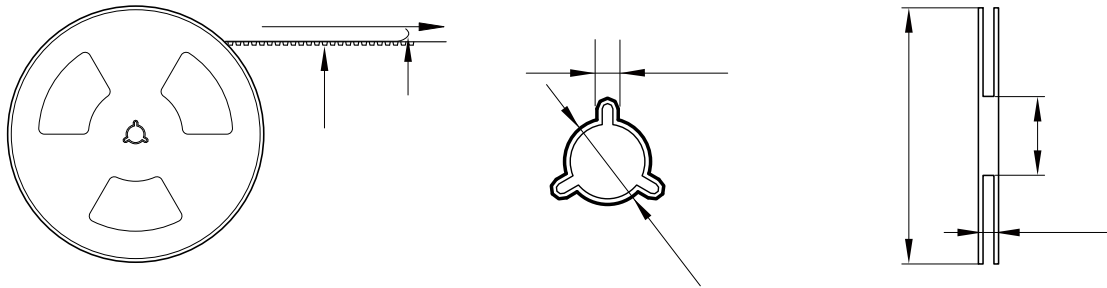

500 Pcs/Reel



2 Reel /Inner box( 1000 Pcs)

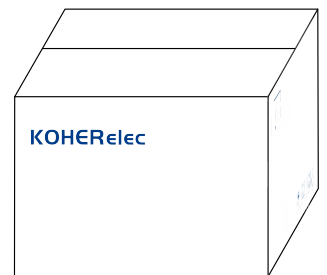

3 Inner box/Carton box(3K Pcs)

:

•

•

•

•

•

•

•

•